

CONTAINER VALVE BE 250/BE 300

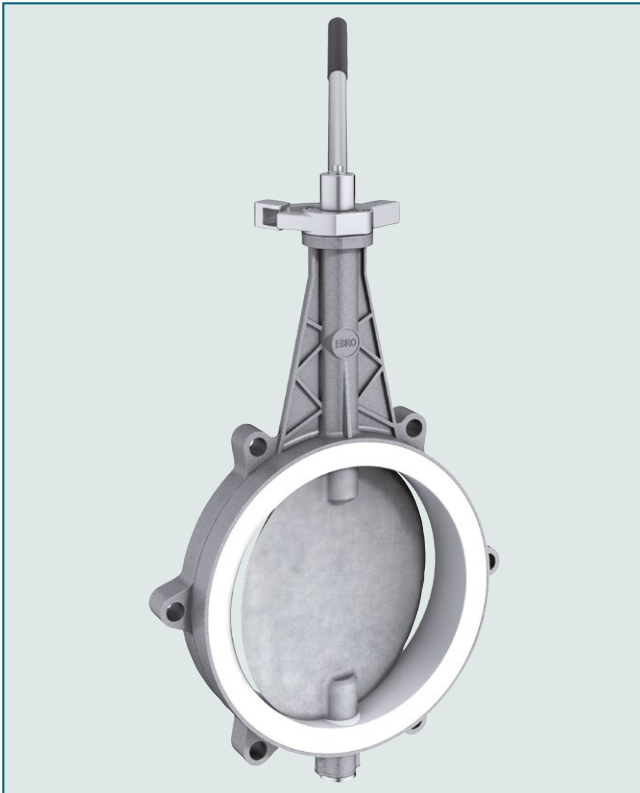

Container valve BE 250 with drain lock bolt.

TECHNICAL DATA

Nominal diameter:	DN 250 / DN 300
Face-to-face:	EBRO works standard
Flange accommodation:	according to the connections in container building
Flange Surface Design:	EN 1092 Form A/B ASME RF, FF
Marking:	EN 19
Tightness check:	EN 12266 (Leakage rate A) ISO 5208, Category 3
Temperature range:	-20°C to +130°C (depending on pressure and medium)
Operating pressure:	max. 1 bar
Body:	Aluminium alloy GD-AlSi9Cu3 (3.2163)
Seat:	EPDM (Ethylene propylene diene monomer rubber) NBR (Nitrile butadiene rubber) FPM (Fluorocarbon rubber) SBR-green (Styrene butadiene rubber)
Disc:	Stainless Steel G-X6CrNiMo18-10 (1.4408) X2CrNiMo17-12-2 (1.4404)

FEATURES

- Shut-off valve for lugging under containers
- Aluminium body
- Suitable for conical containers
- Possibilities for hand operation:
 - drain lock bolt
 - tilting lever
 - engage lever OPEN/CLOSE
- Multiple shaft bearing
- Maintenance-free
- Can be disassembled, material-specific recycling possible

GENERAL APPLICATIONS

- Container building
- Silos



CONTAINER VALVE BE 250/BE 300

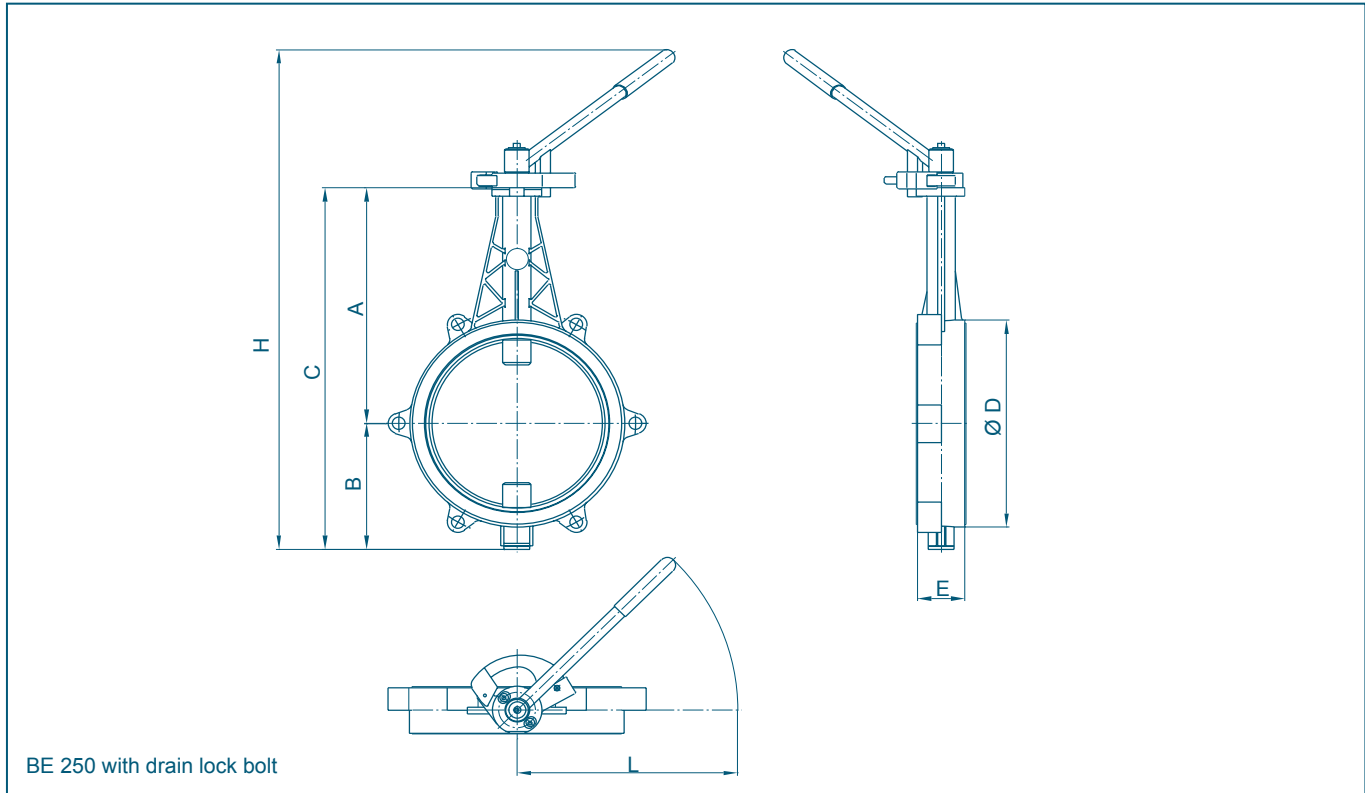

DN [mm]	Size [in]	Dimensions [mm]							Weight [kg]
		A	B	C	D	E	H	L	
250	10	346	185	531	304	68	778	384	6,2
300	12	274	226	500	355	78	742	384	8,9

Subject to change without notice